

Remote Satellite Data Module

RST600 **Installation and** **User Manual**



Beam Communications Pty Ltd

RST600

Installation and User Manual

Beam Communications Pty Ltd

**8 Anzed Court, Mulgrave,
Victoria, 3170, AUSTRALIA**

Information furnished by Beam Communications Pty Ltd (Beam) is believed to be accurate and reliable. However, no responsibility is assumed by Beam for its use, or for any infringement of patents or other rights of third parties, which may result from its use. No license is granted by implication or otherwise under any patent or patent rights of Beam. Beam reserves the right to change specifications at any time without notice.

Copyright © 2009 Beam Communications Pty Ltd. All rights reserved

Product name: RST600 Installation & User Manual

Manual revision: 05

Part Number USRMAN000705

Issue Date: May 2009

Contents

CONTENTS	3
SAFETY INFORMATION	4
ABOUT BEAM COMMUNICATIONS.....	5
CONVENTIONS IN THIS MANUAL.....	6
WHAT IS THE RST600?	7
PACKAGE CONTENTS.....	8
OPTIONAL BEAM ACCESSORIES	8
RST600 INSTALLATION OVERVIEW.....	9
INSTALLING THE RST600	10
MOUNTING THE RST600	11
CONNECTING THE ANTENNA CABLE	12
CONNECTING THE POWER & DATA CABLES	14
SPECIFICATION SUMMARY	16
RS232 SPECIFICATION	17
PHYSICAL CONNECTION	17
RS232 PORT SIGNAL SUPPORT AND HANDSHAKING	17
RS232 PORT ELECTRICAL PARAMETERS.....	18
DATA CONNECTIVITY	18
9522B PHYSICAL SPECIFICATIONS	19
CONNECTOR SPECIFICATIONS	21
MOUNTING BRACKET PHYSICAL SPECIFICATIONS	23
TROUBLESHOOTING THE RST600	24

Safety Information



Note:

Read the following information before installing and using the BEAM RST600. Failing to follow instructions may compromise the safety of the product and may result in personal injury and/or equipment damage. Please consult your supplier if you have any further questions.

Your RST600 is a low power radio transmitter and receiver. When it is ON, it receives and sends out radio frequency (RF) signals.

The design of your RST600 system complies with international safety standards.

Refer to the appropriate section of the *RST600 User Manual* for additional relevant safety information.



WARNING:

Do not open equipment. There are no user-serviceable parts inside.

If a DC power supply is to be used and connected to the DC leads, its output must comply with the Safety Extra Low Voltage (SELV) requirements of IEC60950.

All connectors must only be connected to equipment ports which comply with the Safety Extra Low Voltage (SELV) requirements of IEC60950.”

About BEAM Communications



Beam Communications, a wholly owned subsidiary of World Reach Limited (WRR), listed on the Australian Stock Exchange, is a world leader in design, manufacture and distribution of specialized communications equipment for the Iridium Satellite Network.

Beam's commitment to be at the forefront has continued to increase its share of the global satellite communications market. Its premium distribution network spans the world.

Recognized as a leading provider of satellite communication solutions, **Beam** specializes in Voice, Data, Tracking and customized solutions. Beam develops innovative products and services to meet market demands and niche applications.

Beam's leading edge products are deployed in a wide range of vertical markets including Maritime, Transport, Government, Defense, Mining, Construction, Forestry, Emergency Services, Relief Aid, Telemetry and Rural Telephony.

Supported by a dedicated team of professionals, **Beam** has developed solid relationships with its peers and network of distributors worldwide.

Beam Communications Pty Ltd

**8 Anzed Court, Mulgrave,
Victoria, 3170, AUSTRALIA**

Web: www.beamcommunications.com

Info: info@beamcommunications.com

Support: support@beamcommunications.com

Tel: +61 3 8588 4500

Fax: +61 3 9560 9055

Conventions in this Manual

Warnings, cautions and notes appear throughout this manual.

They are represented by following conventions.



WARNING:

This symbol and associated text indicate a warning note providing information to prevent personal injury or damage to equipment.



Note:

This symbol and associated text indicate a note providing general operating information.



Interference:

All wireless phones may get interference, which could affect performance.



Record:

Write details of your unit for easy reference when required. Ideal when troubleshooting.

What is the RST600?



The RST600 uses the Iridium 9522B L-Band Transceiver Module as a dedicated Remote Satellite data only module designed to provide a reliable and cost effective data service connection when a wired connection is not available.

It does this by providing a standard interface to the Iridium network — a satellite-based, wireless communications network that enables remote communication. The RST600 allows the connection of standard data terminals and other telecommunications devices.

The RST600 from Beam Communications brings you all the convenience and ease of use of a Data Service anywhere in the world using the Iridium Satellite system.

The data services available on the RST600 terminal include

- Circuit Switched Data
- Short Message Service (SMS)
- Short Burst Data (SBD)

Package Contents

- 1 x 9522B Iridium Transceiver
- 1 x Mounting Bracket (base plate) with mounting holes & D25 Connection
- 1 x Data & Power Interface cable assembly to support D25 Connection
- 1 x Data & Power Interface cable for use in a compact installation
- 1 x DC Power Cable
- 1 x User manual in hard copy
- 1 x Beam Starter CD including AT command set
- 1 x AC Mains / 12VDC Plug Pack

Optional Beam Accessories

RST710	Fixed Mast Antenna
RST715	Magnetic Mount Antenna
RST720	Bolt Mount Antenna
RST985	Serial to USB Converter Cable

See your Service Provider for pricing and availability of these optional accessories



Note:

The RST600 is supplied with the ability use a fixed mounting plate with the supplied D25 connector for serial data and power or alternatively for a compact installation the transceiver can be installed on its own using the supplied compact cable.



RST600 Installation Overview

Standard Installation using Base-plate

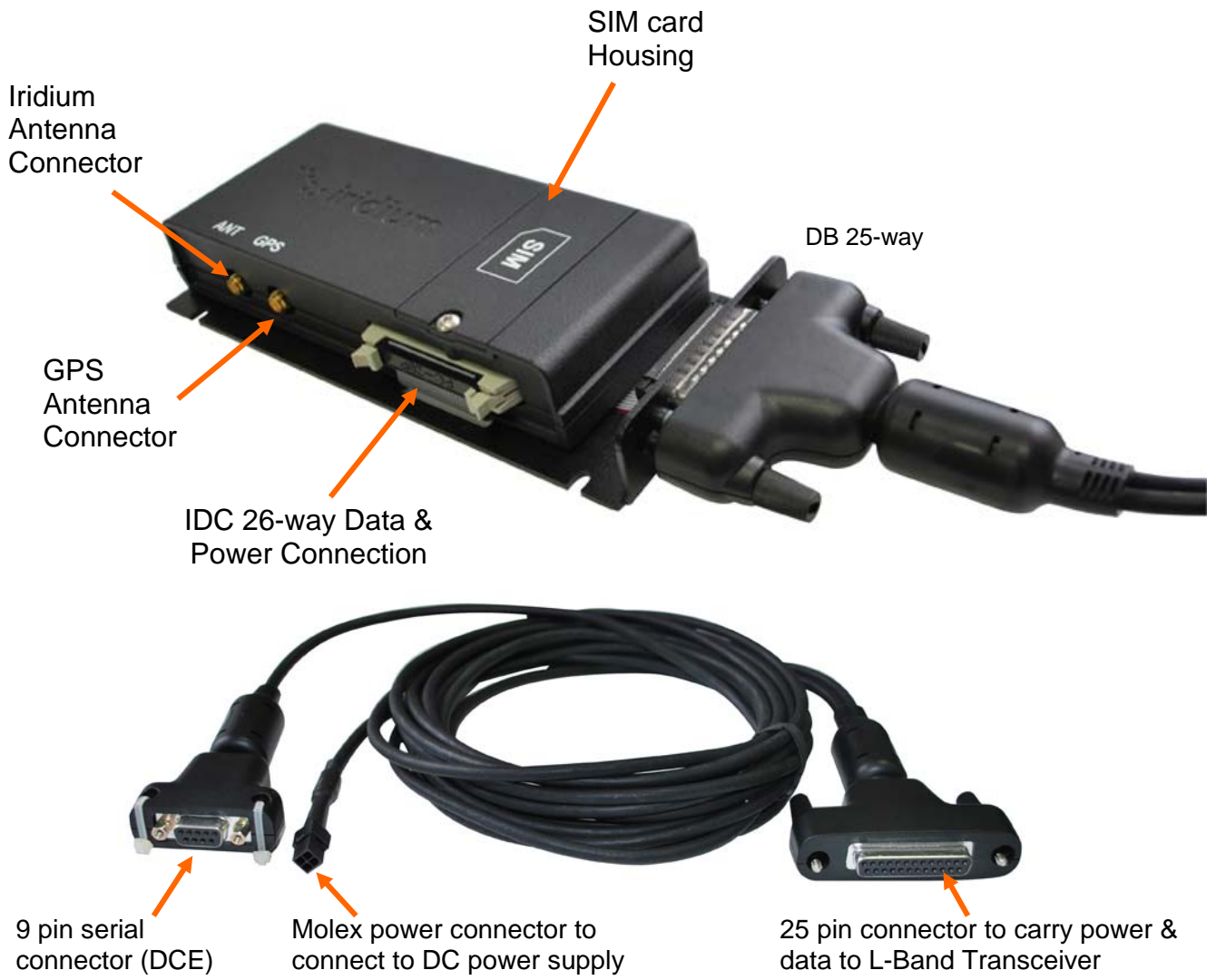

Compact Installation

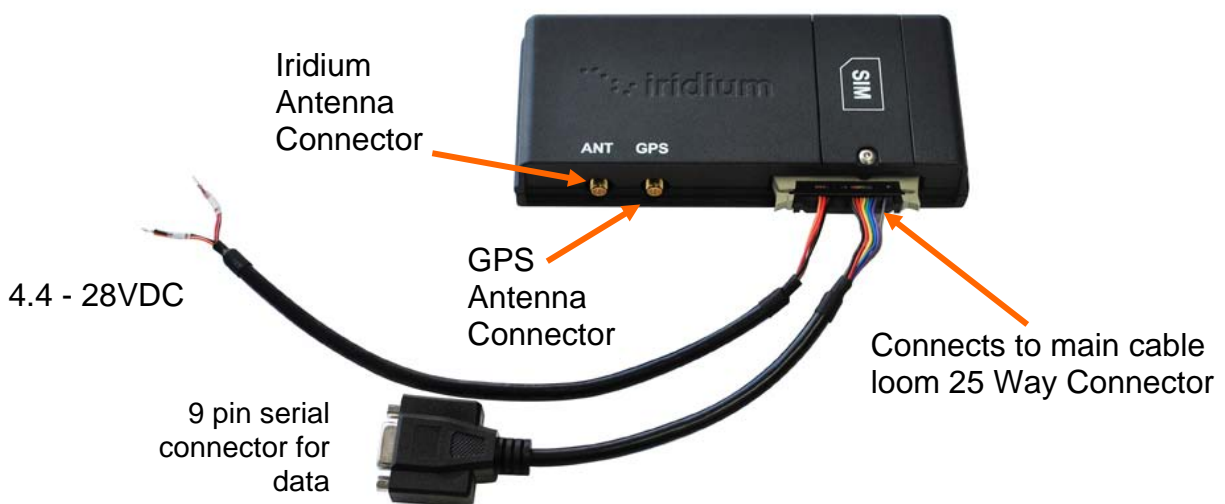

Installing the RST600



Warning:

Make sure the power is Not connected to the RST600 before you insert or remove the SIM card. If you do not, the memory on your SIM card may be damaged.

Installing / Removing the SIM Card

1. Use the supplied Allen key (socket wrench) to remove the screw on the transceiver module to remove the SIM card cover plate as shown. Keep the screws in a safe place whilst you install / remove the SIM card.

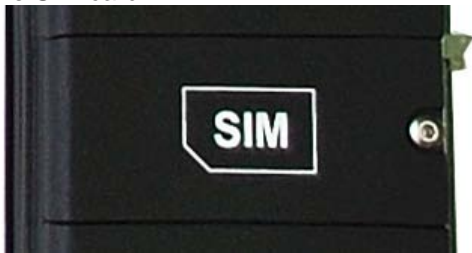

2. Once the cover is removed slide the plastic SIM card holder sleeve (opposite direction of the arrow) to release it from the locked position.

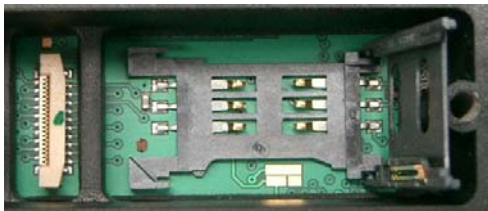

3. Insert the SIM card as shown, with the golden connectors facing inwards and the 'cut corner' of the SIM card facing uppermost.

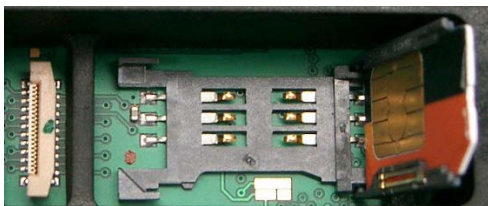

4. Close the plastic sleeve down, and slide in the direction of the arrow until you feel it click into place.



5. Replace the cover, and fasten the screw.



Scratching or bending the SIM card can easily damage the card or its metal contacts. So handle the SIM card with care. Avoid exposing the card to static electricity, water or dirt.

Mounting the RST600



Mounting Bracket Installation

The RST600 is designed to be installed using the supplied base mounting plate or alternatively as a compact standalone module. The base mounting plate provides 3 slots (4mm) for screwing for securing the base plate to an appropriate surface to hold the transceiver module.

The screws should be installed to avoid contact with any of the cable assemblies attached to the module.

(For quick installation: the RST600 is supplied pre-assembled base-plate to 9522B as shown above)

Connecting the Antenna Cable

Iridium
Antenna
Connector



GPS
Antenna
Connector

1. The Iridium transceiver module is fitted with two antenna connectors, one for GPS and one for satellite. Ensure that antenna is connected to the ANT connection and not the GPS output.
2. The “ANT” antenna connection is a Female SMA connector and should be connected directly to your antenna cable or alternatively use the “SMA-Male to TNC-Female converter” included in the kit if required.
3. The “GPS” output enables a GPS module that may be used in conjunction with an RST600 to share the same antenna due to the Iridium and GPS frequencies being close together.
4. When connecting your required antenna cable to the transceiver module, ensure that you fasten the antenna cable securely to the TNC or jack by screwing the cable firmly all the way in with your fingers.
5. It is advisable to always install the RST600 in a location that minimizes the distance between the Antenna and the transceiver module to avoid signal loss.
6. Please refer to the Iridium Antenna Guide for important information on installation and placement of your antenna.

GPS Feed Through Specification

The GPS feed through connector is provided to allow an Iridium 9522B and a GPS module to share a single antenna. Then the GPS receiver module can be connected to the GPS feed through connector output on the 9522B. When the 9522B is powered **but not transmitting**, any GPS signal received on the antenna is passed through to the GPS output. Either a passive or an active GPS module can be connected to the 9522B GPS port.

The gain from the 9522B antenna input to the GPS connector is 0dB (+/- 2dB). The GPS output is available at all times when the 9522B is powered, except during the transmit cycle. (During the transmit cycle there will be some energy at the Iridium frequency which may adversely affect the AGC system of some GPS receivers.)



NOTE: THE TRANSCIEVER MODULE DOES NOT HAVE A GPS ENGINE INSIDE

The GPS antenna input is feed-through only. You will need your own GPS device to make use of the GPS antenna connector.

The RF interface of the GPS feed through connector is summarized in Table 9 below.

General RF Parameters

Parameter	Value
Frequency Range	1575 MHz
Output Impedance	50Ω
Insertion Loss	+/-2dB
Noise Figure	≤7dB

This should provide adequate signal for most GPS receivers because the Iridium antenna will already be well sited. If the Iridium antenna is being shared with GPS then it is important to use an antenna with adequate gain at 1575MHz.



Note: Refer to the Antenna Installation Guide supplied with your RST600 for information on installing the antenna and assuring Quality of Service.

This guide is also available for download at www.beamcommunications.com

Connecting the Power & Data Cables

Standard Installation - Using Base Plate

1. Connect the D25 connector from the main cable loom to the D25 connector on the base plate of the RST600, secure the cable with the thumb screws of the cable assembly.
2. Before connecting power to the power input of the cable assembly ensure that you have installed the SIM card in the unit and replaced the SIM socket cover.
3. The RST600 can now be connected directly to a +4.4VDC to +28VDC input using the DC cable assembly provided, **OR** use the AC plug pack supplied if required for use in an AC mains supply installation.

DC Lead
(nom. +4.4V to
+28VDC)



OR



AC/DC 12V
Plug Pack

4. The DB9 Connector provides the Communications Serial port (DCE) to the Iridium Transceiver terminal, this connects directly to a terminal or logging device (DTE) as required.
5. The RST600 is now ready for use.

The unit should be installed to ensure that the connectors remain accessible after installation for ease of service or disconnection when required.

If using the DC Lead, please ensure that the DC battery / power supply is within the specifications required in the "Specifications" section.

WARNING:



The 9522B is intended to be supplied from a limited power source with a fuse or equivalent protection device of no more than 3A. It is the responsibility of the installer to ensure that the complete system (of which the 9522B forms a part) complies with EN60950-1 or UL60950-1 as applicable. In particular the complete system must be capable of withstanding the 10kV surge test from clause 7 of this standard if its power source is derived from a mains adapter.

Damage may result if the LBT is operated outside of the main input voltage DC limits.

Compact Installation - Removal of Base Plate

1. If required, remove the 4 mounting screws from the bottom side of the mounting plate.
2. Remove the standard 25-way ribbon cable.
3. Connect the supplied shorter 26-way IDC to DB9 data and power cable assembly. Please ensure that the DC battery / power supply is within the specifications required in the "Specifications" section.
4. The DB9 Connector provides the Communications Serial port (DCE) to the Iridium Transceiver terminal, this connects directly to a terminal or logging device (DTE) as required. If required, the hex-4-40UNC nuts can be un-screwed from the DB9 connector.
5. The RST600 is now ready for use.



The 9522B LBT incorporates (6) mounting holes on its bottom surface that can aid in its mounting. "See 9522B Physical Specifications – Rear Mounting Specification".



Note: Do not alter the cables provided or attempt to use different cables as part of the installation for power and data, consult Beam Technical Support for further assistance www.beamcommunications.com



WARNING:

The 9522B is intended to be supplied from a limited power source with a fuse or equivalent protection device of no more than 3A. It is the responsibility of the installer to ensure that the complete system (of which the 9522B forms a part) complies with EN60950-1 or UL60950-1 as applicable. In particular the complete system must be capable of withstanding the 10kV surge test from clause 7 of this standard if its power source is derived from a mains adapter.

Damage may result if the LBT is operated outside of the main input voltage DC limits.

Specification Summary

RST600

Electrical	
9522B Main Input (nominal)	+4.4VDC to +28VDC
9522B Main Input (max limits)	+4.0VDC to +32VDC
9522B Main Input – Ripple	<=40mV peak to peak (measured at 9522B)
RST600 Plug-pack	Input: 90-250VAC 50/60Hz, Output: 12VDC, 3.75A.
Power Consumption (Average)*	<i>(Eg. at +5 VDC Main Input, using DC Lead)</i>
Standby Mode	300mA (~1.5W)
Talk/Transmit Mode	800mA [2.5A Max during call peaks] (~4W)
Modem Type	AT Hayes Compatible
Data speed	2400 bps
EMC Compliance	C-Tick and A-Tick, CE mark
Environmental	
Operating Temperature Range	-30°C to +60°C ambient
Operating Humidity Range	25-75% RH non-condensing
Storage temperature	-40C to +85C
Weight	0.6 kg / 600 grams (Transceiver Only 420 grams)
Dimensions	82 x 186 x 30mm
RF Interface (L-Band Transceiver)	
Frequency range	1616MHz to 1626.5MHz
Average Power	7W during a transmit slot (max)
Average Power	0.6 W during a frame (typical)
Receiver Sensitivity	-118.5 dBm at 50W (typical)
Receiver Spurious Rejection at offsets > 1 MHz (typical)	60 dB
Duplexing method	TDD (Time Domain Duplex)
Oscillator stability	±1.5ppm
Input/output impedance	50 Ohms – TNC F Connector
Multiplexing method:	TDMA/FDMA

* NOTE: The average power consumption depends on the view of the satellite constellation from the Antenna, please ensure maximum view of sky to obtain lowest power usage, and optimum performance.

RS232 Specification

The RST600 is provided with an RS232 serial port for data connection. The 9-pin D-type (female) socket is wired DCE for connection to a standard PC with a 1:1 cable.

Physical Connection

The pin-out of both connectors is described in the following table:

Pin	Signal	Direction	Description
1	DCD	RST → PC	Data Carrier Detect
2	RXD	RST → PC	Received Data
3	TXD	PC → RST	Transmitted Data
4	DTR	PC → RST	Date Terminal Ready
5	GND		Signal Ground (Common)
6	DSR	RST → PC	Data Set Ready (CTS and DCD)
7	RTS	PC → RST	Request to Send
8	CTS	PC → RST	Clear to Send
9	RI	RST → PC	Ring Indicate

RS232 Port Signal Support and Handshaking

The Data port supports full software XON/XOFF handshaking on data (AT commands bypass this as usual for Hayes modems) or full hardware handshaking on RTS/CTS with DCD carrier indication.

RS232 Port Electrical Parameters

The LBT Data Port conforms to the RS232 interface specification with the following parameters:

Parameter	Specification
Communication Rate	220 to 115,200 Baud
Protocol	1 start bit, 8 data bits, no parity, 1 stop bit, asynchronous.
Voltage Levels and sensitivity	RS232 compliant

Data Connectivity

To connect your RST600 to a PC or laptop, connect the 9-pin serial plug from your RST600 interface cable to a 9-pin (Male) port on your PC or laptop.

If you do not have a serial port on your PC / laptop, an *RST985 Serial to USB Converter Cable* is available from your supplier.

For information on how to setup a data call to / from your RST600 or information on sending SMS / SBD, please refer to the *Beam Data Guide*.

For more information, please visit www.beamcommunications.com

9522B Physical Specifications

The overall dimensions of the 9522B LBT and its weight are summarized in the table below. Dimensioned views of the 9522B LBT are shown in the following images. All dimensions are in mm unless otherwise stated.

Physical specifications

Parameter	Value
Length	162mm (6.38")
Width	81mm (3.16")
Depth	28mm (1.10")
Weight (approximate)	420g

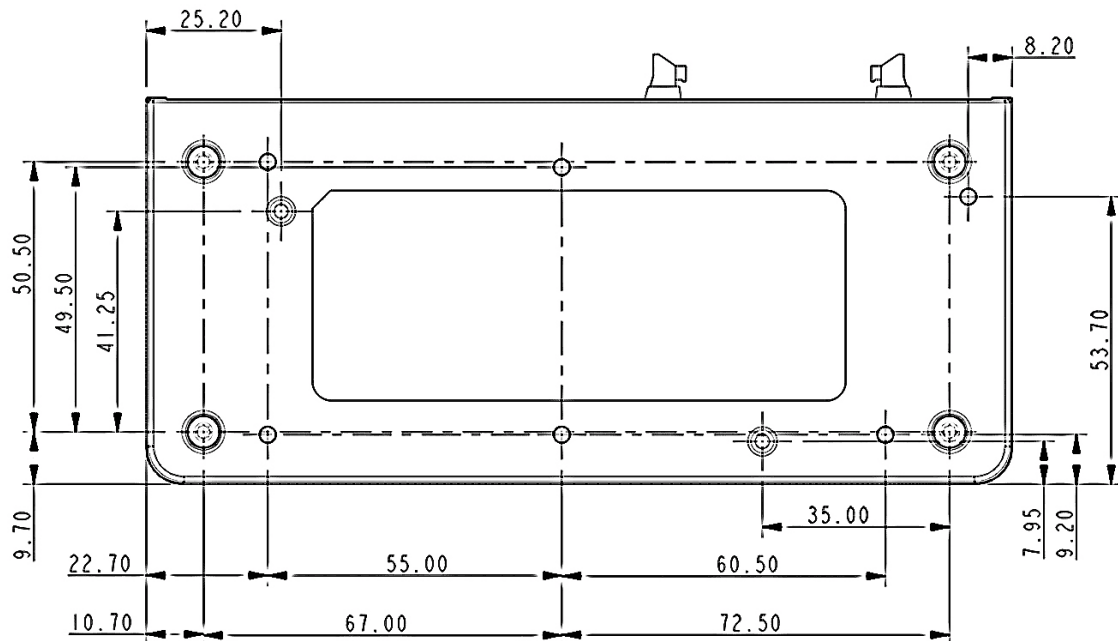

Rear Mounting Specification

It is recommended that a thread-forming screw be used to mount the 9522B LBT via these features. Particularly, a Textron Camcar® Taptite® II Thread-Rolling Fastener of M3.5x0.6 thread type is recommended. This fastener has a 15IP Torx Plus® pan head and is available in lengths of 6, 8, 12, 16, and 20 mm as part number 3BE-P802-00, 3BE-P803-00, 3BE-P8185-00, 3BE-P804-00, 3BEP8186-00, and 3BE-P8187-00 respectively.

RST600 INSTALLATION & USER MANUAL

Length should be chosen to **ensure that penetration into the 9522B LBT housing does not exceed 11 mm**. If a 6-32 thread type is desired, a Textron Camcar® Taptite® II Thread-Rolling Fastener with a 15IP Torx Plus® pan head is available in lengths of 1/4, 5/16, 3/8, 1/2, 5/8, 3/4, and 1 inch as part number 3BE-P814-00, 3BE-P8123-00, 3BE-P815-00, 3BE-P816-00, 3BE-P8124-00, 3BE-P817-00, and 3BE-P818-00 respectively. A 10IP Torx Plus® flat head version is also available in a single length of 1/2 inch as part number 3BE-P801-00. Another 6-32 thread type option is to insert a helical coil insert with a 6-32 internal thread into these features thus accommodating 6-32 threaded fasteners as mounting hardware for the 9522B LBT. National Aerospace Standard NASM122238 serves as a technical reference for the recommended helical coil insert.

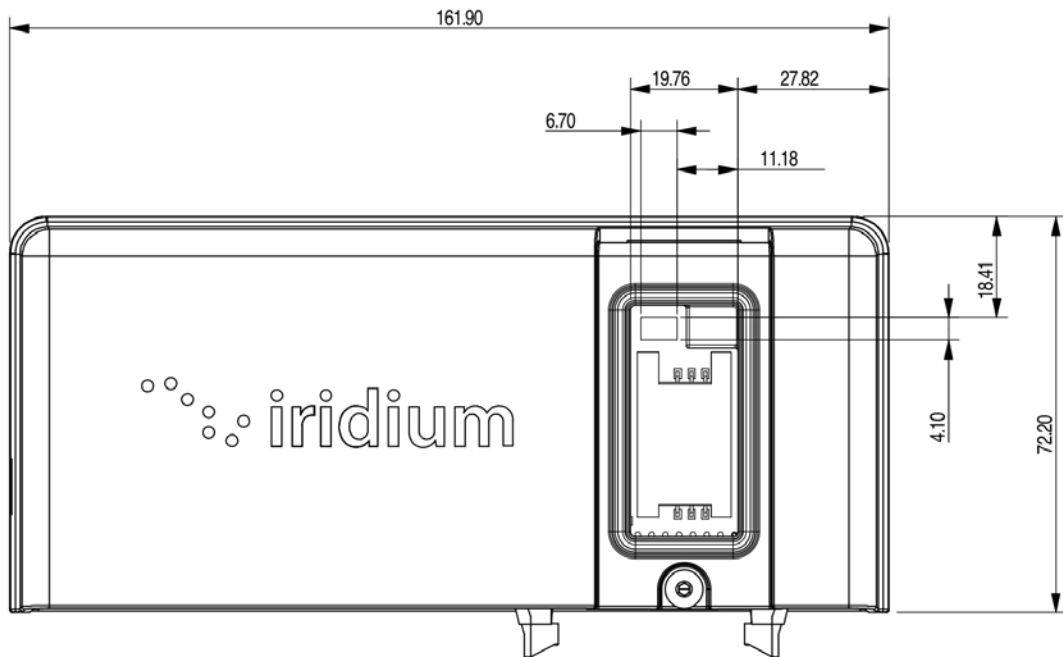

CONNECTOR SPECIFICATIONS

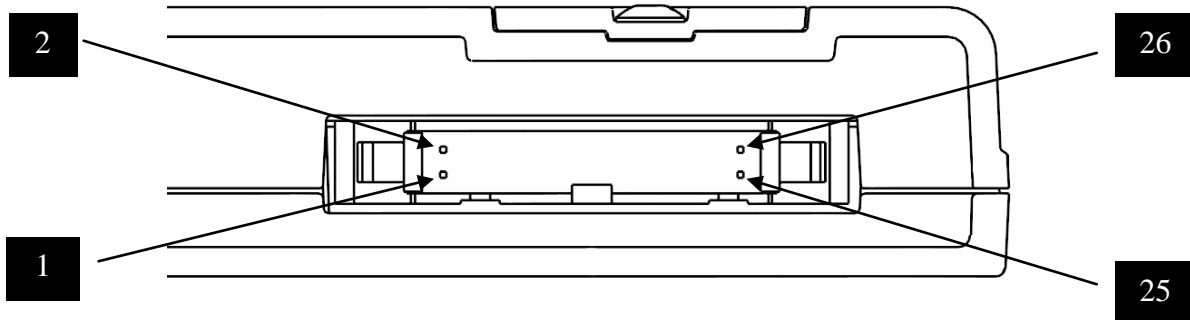

Pin Identification on 26-way connector

26-Way connector Pin-out (from 9522B)

Contact	Signal	Description
1	EXT_ON_OFF	External connection for On / Off key input to LBT
2	0V	Signal ground, 0V signal reference and return
3	EXT_11HZ	90ms "frame sync" signal (used in testing)
4	MIC_AUD	Microphone audio input to LBT
5	EXT_GND	Power Ground input to LBT
6	EXT_PWR	Power input to LBT
7	EXT_PWR	Power input to LBT
8	EXT_GND	Power Ground input to LBT
9	SPKR_AUD	Speaker audio output from LBT
10	DPL_TX	Digital Peripheral Link (UART) data output from LBT
11	DA_TX	PCM digital audio output from LBT
12	DF_DTR	Data / Fax Data Terminal Ready input to LBT
13	DF_RI	Data / Fax Ring Indication output from LBT
14	DPL_RX	Digital Peripheral Link (UART) data input to LBT
15	DF_RTS	Data / Fax Request to Send input to LBT
16	DF_DSR	Data / Fax Data Set Ready output from LBT
17	DF_S_TX	Data / Fax (UART) data input to LBT
18	DF_CTS	Data / Fax Clear to Send output from LBT
19	DF_DCD	Data / Fax Data Carrier Detect output from LBT
20	0V	Signal ground, 0V signal reference and return
21	DA_FS	PCM digital audio frame sync output from LBT
22	DA_RX	PCM digital audio input to LBT
23	DA_CLK	PCM digital 2.048MHz audio clock output from LBT
24	0V	Signal ground, 0V signal reference and return
25	DF_S_RX	Data / Fax data (UART) output from LBT
26	NETWORK_AVAILABLE	Network available output from LBT

25-Way D Connector Pin-out (from base-plate)

Contact	Signal	Description
1	EXT_ON_OFF	External connection for On / Off key input to LBT
2	EXT_11HZ	90ms "frame sync" signal (used in testing)
3	EXT_GND	Power Ground input to LBT
4	EXT_PWR	Power input to LBT
5	SPKR_AUD	Speaker audio output from LBT
6	DA_TX	PCM digital audio output from LBT
7	DF_RI	Data / Fax Ring Indication output from LBT
8	DF_RTS	Data / Fax Request to Send input to LBT
9	DF_S_TX	Data / Fax (UART) data input to LBT
10	DF_DCD	Data / Fax Data Carrier Detect output from LBT
11	DA_FS	PCM digital audio frame sync output from LBT
12	DA_CLK	PCM digital 2.048MHz audio clock output from LBT
13	DF_S_RX	Data / Fax data (UART) output from LBT
14	0V	Signal ground, 0V signal reference and return
15	MIC_AUD	Microphone audio input to LBT
16	EXT_PWR	Power input to LBT
17	EXT_GND	Power Ground input to LBT
18	DPL_TX	Digital Peripheral Link (UART) data output from LBT
19	DF_DTR	Data / Fax Data Terminal Ready input to LBT
20	DPL_RX	Digital Peripheral Link (UART) data input to LBT
21	DF_DSR	Data / Fax Data Set Ready output from LBT
22	DF_CTS	Data / Fax Clear to Send output from LBT
23	0V	Signal ground, 0V signal reference and return
24	DA_RX	PCM digital audio input to LBT
25	0V	Signal ground, 0V signal reference and return

Antenna Connector

The 9522B LBT provides a single 50Ω, SMA type antenna connector. This mates with a standard SMA plug, for example Radiall R125.072.000 (straight) or R125.172.000 (right-angle). An adaptor is available to convert this connector to TNC to enable the 9522B to be used as a replacement for a 9522A.

This port must be connected to an approved antenna, located with a clear view of the sky. If the GPS feed-through is being used then this antenna must also have sufficient sensitivity at GPS frequencies.

GPS Feed Through Connector

9522B LBT passes the received signal through to this 50Ω, SMA type connector, which mates with a standard SMA plug, for example Radiall R125.072.000 (straight) or R125.172.000 (right-angle). It is intended that this be connected to a GPS receiver. Note that this signal will be de-graded during a call.

Mounting Bracket Physical Specifications

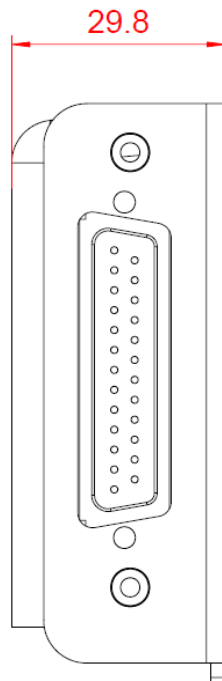
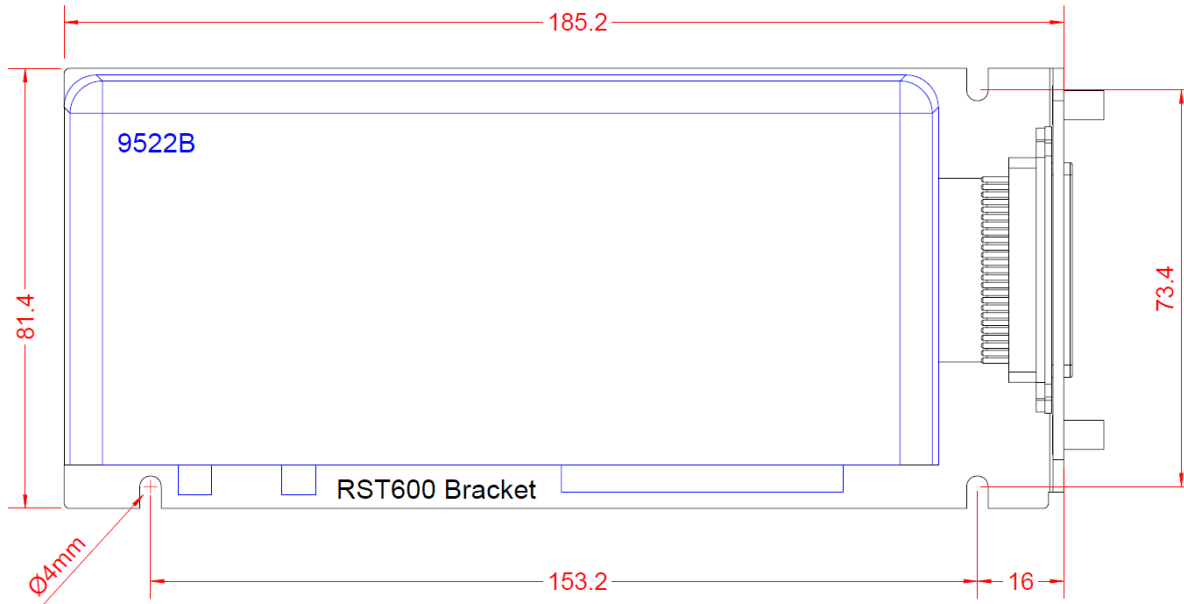

Troubleshooting the RST600

This chapter provides information to help you troubleshoot problems you may encounter while running the RST600.

Q	No power on RST600
A	Check power is connected and AC available to the plug pack

Q	RST600 fails to register with the Iridium service after 30 seconds
A	<p>Check power connection</p> <p>Check Antenna connection and location</p> <p>Ensure SIM is inserted</p> <p>Check correct power supply is being used</p> <p>Ensure that the SIM PIN (if required) has been entered</p>

Q	PC cannot connect to RST600
A	Check that the correct cable is used on the correct port, and that the bit rate is set the same for both PC and RST600

Q	Your PIN2 is locked.
A	Enter the PIN2 unblocking key (PUK2) or contact your service provider.

Q	Your SIM card won't work.
A	<ul style="list-style-type: none"> • Is the card inserted the correct way? • Is the SIM gold chip visibly damaged or scratched? Return the card to your service provider. • Check the SIM and phone contacts. If they are dirty, clean them with an antistatic cloth.

Q	Your PIN is blocked
A	<ul style="list-style-type: none"> • Check Card or Insert Card. • Check the card is inserted correctly • Check the contacts of the card are clean • Clean the chip with a soft cloth • See your Service Provider if continues • Enter the PIN unblocking key (PUK1) or contact your service provider

Q	You can't make calls.
A	<p>Check that the antenna is properly mounted. Do you have a clear view of the sky?</p> <p>Did you enter the number in international format?</p> <p>All calls made from the Iridium System require a special calling sequence; please refer to your Service Provider for these details.</p> <p>Check the signal strength meter. If the signal is weak, move the antenna to a more open area.</p> <p>Check the Network Selection settings.</p> <p>Check your Operator coverage map.</p> <p>Is Restricted displayed? Check the Call Barring setting.</p> <p>Has a new SIM card been inserted?</p>

Q	You can't receive calls
A	<p>Check to see that your phone is powered on.</p> <p>Check the antenna. Is it properly mounted? Do you have a clear view of the sky?</p> <p>Check the signal strength. If the signal is weak, move the antenna to a more open area.</p> <p>Check the Call Forwarding and Call Barring settings.</p>

Q	You can't make international calls.
A	Have you included the relevant codes? Press and hold the (+) key to display the international dialling prefix (+), and then enter the appropriate country code, followed by the phone number.

Q	You can't cancel call forwarding or call barring
A	Wait until you are in an area with good network coverage and try again.

For additional product support:

BEAM Communications Pty Ltd
8 Anzed Court, Mulgrave
Victoria, 3170, AUSTRALIA

Web: www.beamcommunications.com
 Info: info@beamcommunications.com
 Support: support@beamcommunications.com
 Tel: +61 3 8588 4500
 Fax: +61 3 9560 9055

BEAM Warranty Conditions



BEAM Communications gives this express warranty (along with extended warranty endorsements, where applicable) in lieu of all other warranties, express or implied, including (without limitation), warranties of merchantability and fitness for a particular purpose. This constitutes our sole warranty and obligation with regard to our products as well as the Customer's sole remedy.

BEAM Communications expressly disclaims all liability and responsibility for any special, indirect or consequential damages or any further loss of any kind whatsoever resulting from the use of our product(s). The Customer's sole and exclusive remedy and the limit of BEAM liability for any loss whatsoever, shall not exceed the purchase price paid by the Customer for the product to which a claim is made.

All products manufactured by BEAM Communications are warranted to be free from defects in material and workmanship in accordance with and subject to the following terms and conditions:

1. This warranty is limited to the original Customer only. It cannot be transferred or assigned to third parties unless the intent to transfer to a third party is expressly indicated in a purchase order and/or warranty-processing arrangements have been agreed upon in writing by BEAM.
2. BEAM Communications does not warrant any installation, maintenance or service of the Products not performed by BEAM, nor does it warrant the use of Products with unapproved ancillary products.
3. BEAM Communications will correct any defects in material or workmanship of products manufactured by BEAM which appear within (12) months, from the date of shipment by BEAM Communications to the Customer. BEAM Communications will repair or replace, at our option, any defective product, provided that our analysis and/or inspection discloses that such defects developed under normal and proper use.
4. This warranty does not extend to goods subjected to liquid or particulate ingress, extreme humidity, misuse, neglect, accident or improper installation, or to maintenance or repair of products that have been altered or repaired by anyone except BEAM Communications unless otherwise stated in writing.
5. The warranty is a return-to-base warranty and freight is paid by the sender.
6. A charge of USD \$125 including return freight will be made for testing returned product which is not defective or is found to be defective as the result of improper use, maintenance or neglect.
7. BEAM Communications will not accept responsibility for any invoiced goods or services that are not covered by a BEAM Communications written purchase order. Under no circumstances do BEAM Communications agree to pay for labour or other related expenses associated with the troubleshooting and/or repair of our product without prior specific written authorization.
8. Information in our descriptive literature is based on product specifications that are current at the time of publication. Product specifications, designs and descriptive literature are subject to change as improvements are introduced. Although we announce changes as they occur, we cannot guarantee notification to every Customer. BEAM Communications warrants delivered product to conform to the most current specifications, designs and descriptive literature.
9. This warranty policy may be expanded or limited, for particular categories of products or Customers, by information sheets published as deemed appropriate by BEAM Communications. The warranty for third party Products is that of the third party and not BEAM warranty.

