



Iridium 9603_(N)

SBD Transceiver Developer's Guide

REVISION 2.1

Iridium Communications Inc.
1750 Tysons Blvd, Suite 1400
McLean, VA 22102
www.iridium.com

Toll Free: +1.866.947.4348 [US Only]
International +1.480.752.5155
email: info@iridium.com

Proprietary & Confidential Information

LEGAL DISCLAIMER AND CONDITIONS OF USE

This document contains information for the Iridium 9603 (“Product”) and is provided “as is.” The purpose of providing such information is to enable Value Added Resellers and Value Added Manufacturers (collectively, “Product Developer(s)”) to understand the Product and how to integrate it into a wireless solution. Reasonable effort has been made to make the information in this document reliable and consistent with specifications, test measurements and other information. However, Iridium Communications Inc. and its affiliated companies, directors, officers, employees, agents, trustees or consultants (“Iridium”) assume no responsibility for any typographical, technical, content or other inaccuracies in this document. Iridium reserves the right in its sole discretion and without notice to you to change Product specifications and materials and/or revise this document or withdraw it at any time. Iridium is not obligated to provide updates, maintenance or technical support to the Product Developer. In no event shall Iridium be obligated to make an Iridium Partner’s solution commercially available. The Product Developer assumes any and all risk of using the Product specifications and any other information provided. If you are dissatisfied with any portion of the Specification, your sole and exclusive remedy is to discontinue use of the Specification.

Your use of this document is restricted to the development activity authorized under the Agreement between you and Iridium and is otherwise subject to all applicable terms and conditions of such Agreement(s), including without limitation software license, limited warranty, conditions of use and confidentiality provisions and the Product Sales Terms and Conditions set forth at <http://www.iridium.com/findresources/LegalNotices.aspx>. Please review your Agreement and the Iridium Product Sales Terms and Conditions that govern your relationship with Iridium. This document is strictly Proprietary and Confidential to Iridium. Consistent with your Partner Agreement with Iridium, you may not disclose the document (or any portion thereof) to others without express prior written permission from Iridium. Any violation of your Agreement's Proprietary and Confidentiality obligations shall result in remedies to the fullest extent available to Iridium at law or in equity.

IRIDIUM MAKES NO REPRESENTATIONS, GUARANTEES, CONDITIONS OR WARRANTIES, WHETHER EXPRESS OR IMPLIED, INCLUDING WITHOUT LIMITATION, IMPLIED REPRESENTATIONS, GUARANTEES, CONDITIONS OR WARRANTIES OF MERCHANTABILITY AND FITNESS FOR A PARTICULAR PURPOSE, NON-INFRINGEMENT, SATISFACTORY QUALITY, NON-INTERFERENCE, OR ACCURACY OF INFORMATIONAL CONTENT, ARISING FROM THE INFORMATION PROVIDED IN THIS SPECIFICATION OR RELATED TO A COURSE OF DEALING, LAW, USAGE, OR TRADE PRACTICE, OR ARISING FROM OR RELATED TO THE PERFORMANCE OR NONPERFORMANCE OF ANY PRODUCTS AND/OR SERVICES, ACCESSORIES, FACILITIES OR SATELLITE SERVICES EXCEPT AS EXPRESSLY STATED IN THE LIMITED WARRANTY. ANY OTHER STANDARDS OF PERFORMANCE, GUARANTEES, CONDITIONS AND WARRANTIES ARE HEREBY EXPRESSLY EXCLUDED AND DISCLAIMED TO THE FULLEST EXTENT PERMITTED BY LAW. THIS DISCLAIMER AND EXCLUSION SHALL APPLY EVEN IF THE EXPRESS LIMITED WARRANTY FAILS OF ITS ESSENTIAL PURPOSE.

IN NO EVENT SHALL IRIDIUM BE LIABLE, REGARDLESS OF LEGAL THEORY, INCLUDING WITHOUT LIMITATION CONTRACT, EXPRESS OR IMPLIED WARRANTY, STRICT LIABILITY, GROSS NEGLIGENCE OR NEGLIGENCE, FOR ANY DAMAGES IN EXCESS OF

THE PURCHASE PRICE OF THE SPECIFICATION, IF ANY, OR THE AMOUNT SET FORTH IN YOUR AGREEMENT. NOR SHALL IRIDIUM BE LIABLE FOR ANY DIRECT, INDIRECT, INCIDENTAL, SPECIAL OR CONSEQUENTIAL DAMAGES OF ANY KIND, LOSS OF REVENUE OR PROFITS, LOSS OF BUSINESS, LOSS OF PRIVACY, LOSS OF USE, LOSS OF TIME OR INCONVENIENCE, LOSS OF INFORMATION OR DATA, SOFTWARE OR APPLICATIONS OR OTHER FINANCIAL LOSS CAUSED BY USE OF THE SPECIFICATION OR THE PRODUCT (INCLUDING HARDWARE, SOFTWARE AND/OR FIRMWARE) AND/OR THE IRIDIUM SATELLITE SERVICES, OR ARISING OUT OF OR IN CONNECTION WITH THE ABILITY OR INABILITY TO USE THE PRODUCT/SERVICE (INCLUDING HARDWARE, SOFTWARE AND/OR FIRMWARE) AND/OR THE IRIDIUM SATELLITE SERVICES, TO THE FULLEST EXTENT THESE DAMAGES MAY BE DISCLAIMED BY LAW AND WHETHER IRIDIUM WAS ADVISED OF THE POSSIBILITIES OF SUCH DAMAGES. IRIDIUM IS NOT LIABLE FOR ANY CLAIM MADE BY A THIRD PARTY OR MADE BY YOU FOR A THIRD PARTY.

Export Compliance Information

This Product is controlled by the export laws and regulations of the United States of America. The U.S. Government may restrict the export or re-export of this Product to certain individuals and/or destinations. Diversion contrary to U.S. law is prohibited. For further information, contact the U.S. Department of Commerce, Bureau of Industry and Security or visit www.bis.doc.gov.

Revision History

Revision	Date	Comment
.9	05-09-12	Iridium 9603 Initial Release
1.0	06-04-12	Iridium Commercial Release
2.0	08-06-12	Added Section 4.2.2 addressing antennae design guidance.
2.1	08-12-14	Added note on the 9603N supply voltage range to supply voltage definitions in Table 7 and Table 9. Added note on the maximum supply droop across the transmit burst for the 9603N in section 3.2. Updated table 1 and 6. Added section 1.6. Updated Power Consumption values in table 9 for 9603N (these values were derived from data in P1443-WM-057 V0.3).

Revision History	4
List of Abbreviations	6
1 Product Overview	7
1.1 Key Features	7
1.2 Transceiver Packaging and Regulatory Certification	8
1.3 Software Revision.....	9
1.4 FCC Warning Statement	9
1.5 Industry Canada Warning Statement.....	9
1.5.1 English.....	9
1.5.2 French	9
1.6 R&TTE Statement	9
2 Physical Specification	11
2.1 Module Dimensions	11
2.2 Mechanical Dimensions – Motherboard Mounting.....	13
2.3 Environmental	16
2.3.1 Environmental Specification	16
2.3.2 Environmental Tests Performed	16
2.4 Physical Interface Connectors	16
3 Electrical Interfaces	17
3.1 User Connector	17
3.1.1 User Connector Type	17
3.1.2 User Connector Pin Allocation.....	18
3.2 DC Power Interface	19
3.2.1 Power On/Off Control	21
3.2.2 Typical Power Usage Profile	21
3.3 Serial Data Interface.....	22
3.4 Network Available Output.....	22
3.5 DC Supply Indicator Output.....	22
4 RF Interface	23
4.1 RF Connector	23
4.2 Antenna Implementation.....	23
4.2.1 Antenna Characteristics	23
4.2.2 Important Design Guidance.....	23
4.3 RF Interface Specifications.....	23
4.4 Radio Characteristics	25
4.5 S-meter Performance	25
5 AT Command Set Description.....	26

List of Abbreviations

Abbreviation	Description
CE	Conformité Européene
CTS	(V.24 signal) Clear To Send. This signal is used to control the flow of data to the Iridium 9603
DC	Direct Current
DCD	(V.24 signal) Data Carrier Detect
DCE	Data Communications Equipment. In this Product, DCE refers to the Iridium 9603
DSR	(V.24 signal) Data Set Ready. This signal, from the Iridium 9603, indicates readiness to accept communication over the data port
DTE	Data Terminal Equipment. In this Product, DTE refers to the FA
DTR	(V.24 signal) Data Terminal Ready. This signal, from the FA, requests the Iridium 9603 to accept communication over the data port
ESS	ETC SBD Subsystem (synonymous with GSS)
ETC	Earth Terminal Controller
FA	Field Application; the application controlling the Iridium 9603
FCC	Federal Communications Commission
GND	Ground
GSS	Gateway SBD Subsystem (synonymous with ESS)
IC	Industry Canada
IMEI	International Mobile Equipment Identity
LBT	L-Band Transceiver
MO	Mobile Originated
MOMSN	Mobile Originated Message Sequence Number
MT	Mobile Terminated
MTMSN	Mobile Terminated Message Sequence Number
RHCP	Right Hand Circular Polarization
RI	(V.24 signal) Ring Indicate. This signal, from the Iridium 9603, indicates that an MT message is present at the GSS
RTS	(V.24 signal) Request To Send. This signal is used to control the flow of data from the Iridium 9603.
SBD	Short Burst Data
SMS	Short Message Service
TBA	To Be Advised
UART	Universal Asynchronous Receiver Transmitter
VAM	Value Added Manufacturer
VAR	Value Added Reseller
VSWR	Voltage Standing Wave Ratio

1 Product Overview

The Iridium 9603 Short Burst Data Only Transceiver (9603) is designed to be integrated into a wireless data application with other host system hardware and software to produce a full solution designed for a specific application or vertical market. Examples of these solutions include tracking a maritime vessel or automatic vehicle location.

The 9603 only supports Iridium’s Short Burst Data (SBD) capability. It does not support voice, circuit switched data, or short message service (SMS).

The 9603 is designed to meet the regulatory requirements for approval for FCC, Canada, and CE assuming an antenna with a gain of ~3 dBi and adequate shielding. This allows the 9603 to be integrated into a variety of wireless data applications or retrofitted into existing SBD-only applications that utilize SBD with the current Iridium 9602, 9601, 9522A, 9522B or 9522 L-Band transceiver-based products. (Note that additional development work will be required). Such finished products, when integrated together, require regulatory and safety testing to be conducted by the integrator.

The 9603 is a single board transceiver provided as a ‘black box’ transceiver module with all device interfaces provided by a single multi-pin interface connector in addition to the antenna connector. The Product only provides the core transceiver. All other end user Field Application functions such as GPS, microprocessor based logic control, digital and analog inputs, digital and analog outputs, power supply and antenna must be provided by the solution developer. The device interface across the user connector consists of a serial-data interface, DC power input, network available output and a power on/off control line.

The 9603 does not incorporate nor require a Subscriber Identity Module (also known as a SIM Card) to be inserted into the Transceiver. The 9603 is intended to be used as a transceiver module fitted within another host system. The 9603 module is designed to comply with the standards for Radio Emissions Compliance, Electromagnetic Compatibility, and AC Safety in the United States, European Union and Canada, for host systems that provide safe connections to power supply and external antenna or cable distribution system.

The Iridium 9603 is described within this document as “Iridium 9603,” “9603 SBD Transceiver,” “Transceiver,” “Modem,” and “ISU.” All of these terms refer to the same product.

1.1 Key Features

- Single board transceiver
- Small form factor
- No SIM card
- Designed to be incorporated into an OEM solution
- Maximum mobile originated message size 340 bytes
- Maximum mobile terminated message size 270 bytes
- Automatic Notification to the Transceiver that a mobile terminated message is queued at the Gateway
- Global operating capability
- RoHS compliant

1.2 Transceiver Packaging and Regulatory Certification

The 9603 SBD Transceiver is a regulatory approved daughter module transceiver that can be fitted within an enclosed host system. With appropriate external connections, the host system can be designed to meet full transceiver regulatory tests and sold as a Regulatory Certified product that meets CE, FCC and IC requirements.

The 9603 has regulatory and technical certifications as shown in Table 1.

Table 1: Regulatory and Technical Certifications.

Regulatory Approvals	Radio Tests	EMC Tests	Electrical / Mechanical / Operational Safety Tests
CE	ETSI EN 301 441 V1.1.1 (2000-05)	ETSI EN 301 489-20 V1.2.1 (2002-11) ETSI EN 301 489-1 V1.9.2 (2011) EN61000-4-2 : 2009 EN61000-4-3 : 2006 + A1: 2008 + A2: 2010 EN61000-4-4 : 2004 + A1: 2010 EN61000-4-6 : 2009 EN55022:2006 + A1: 2007	EN60950-1:2006 + A11: 2009 + A1: 2010 + A12: 2011
FCC	FCC CFR47 parts 2 (2013), 15B (2013), and 25 (2013)		
Industry Canada	Industry Canada RSS170 Issue 2, March, 2011 Industry Canada RSS-GEN Issue 3, December, 2010		

1.3 Software Revision

Product Developers should read this document in conjunction with the “Software Release Notes” relevant to the revision of the software that is loaded into their Iridium 9603 SBD Transceiver.

Product Developers should take into account in their software design that it is possible that a transceiver may have an earlier software release and may therefore have different capabilities to those listed in this document. Product Developers are advised to ensure that production procedures for finished goods confirm that the software used in the Product Developer application is designed for the Software Release loaded in the Iridium 9603 SBD Transceiver. This can be read out of the module using the AT command interface. A software upgrade utility is provided with each SW release. The utility runs on a Windows compatible OS and will automatically upgrade the modem with the latest version.

1.4 FCC Warning Statement

- This device complies with Part 15 of the FCC Rules. Operation is subject to the following two conditions:
 - 1) This device may not cause harmful interference, and
 - 2) This device must accept any interference received, including interference that may cause undesired operation.
- This equipment complies with FCC radiation exposure limits set forth for an uncontrolled environment. End users must follow the specific operating instructions for satisfying RF exposure compliance. This transmitter must not be co-located or operating in conjunction with any other antenna or transmitter.
- Changes or modifications not expressly approved by the party responsible for compliance could void the user's authority to operate the equipment.

1.5 Industry Canada Warning Statement

1.5.1 English

Under Industry Canada regulations, this radio transmitter may only operate using an antenna of a type and maximum (or lesser) gain approved for the transmitter by Industry Canada.

To reduce potential radio interference to other users, the antenna type and its gain should be so chosen that the equivalent isotropically radiated power (e.i.r.p.) is not more than that necessary for successful communication.

This device complies with Industry Canada license-exempt RSS standard(s). Operation is subject to the following two conditions: (1) this device may not cause interference, and (2) this device must accept any interference, including interference that may cause undesired operation of the device.

1.5.2 French

Conformément à la réglementation d'Industrie Canada, le présent émetteur radio peut fonctionner avec une antenne d'un type et d'un gain maximal (ou inférieur) approuvé pour l'émetteur par Industrie Canada.

Dans le but de réduire les risques de brouillage radioélectrique à l'intention des autres utilisateurs, il faut choisir le type d'antenne et son gain de sorte que la puissance isotrope rayonnée équivalente (p.i.r.e.) ne dépasse pas l'intensité nécessaire à l'établissement d'une communication satisfaisante.

Le présent appareil est conforme aux CNR d'Industrie Canada applicables aux appareils radio exempts de licence. L'exploitation est autorisée aux deux conditions suivantes : (1) l'appareil ne doit pas produire de brouillage, et (2) l'utilisateur de l'appareil doit accepter tout brouillage radioélectrique subi, même si le brouillage est susceptible d'en compromettre le fonctionnement.

1.6 R&TTE Statement

Iridium Communications Inc. hereby declares that the 9603N is in compliance with the essential requirements and other relevant provisions of Directive 1999/5/EC. A copy of the Declaration of Conformity is given below.



E C Directive

Declaration of Conformity

We, Iridium Communications Inc. of 1750 Tysons Blvd, Suite 1400, McLean, VA 22102 USA declare under our sole responsibility that the product 'Iridium 9603N Short Burst Data Modem' to which this declaration relates, is in conformity with the following standards and/or other normative documents:

Standard	Description
EN60950-1:2006 + A11:2009 + A1:2010 + A12:2011	Information technology equipment – Safety – Part 1: General requirements Assessment of electronic and electrical equipment related to human exposure restrictions for electromagnetic fields (0 Hz - 300 GHz)
EN 62311:2008	
EN301 489-20 V1.2.1 (2002- 11)	Electromagnetic compatibility and Radio Spectrum Matters (ERM)
EN301 489-01 V1.9.2 (2011)	Electromagnetic Compatibility (EMC) standard for radio equipment and services
ETSI EN 301 441 V 1.1.1 2000-05	Satellite Earth Stations and Systems (SES); Harmonised EN for Mobile Earth Stations (MESs)

We hereby declare that all essential radio test suites have been carried out and that the above named product is in conformity to all the essential requirements of Directive 1999/5/EC.

The conformity assessment procedure referred to in Article 10 and detailed in Annex IV of Directive 1999/5/EC has been followed with the involvement of the following Notified Body:
TÜV SÜD BABT TCB, Octagon House, Concorde Way, Segensworth North, Fareham, Hampshire, PO15 5RL, UK.

The technical documentation relevant to the above equipment will be held at Iridium Communications Inc., 1750 Tysons Blvd, Suite 1400, McLean, VA 22102 USA.



Hermon Pon
VP of Technology Development and Network Engineering
Iridium Satellite
July 31, 2014

1750 Tysons Boulevard, Suite 1400 | McLean, VA | 22102 USA
tel: +1.703.287.7400 | fax: +1.703.287.7450

www.iridium.com



2 Physical Specification

For illustrative purposes a picture of the Iridium 9603 SBD Transceiver Module is shown in Figure 1.

P

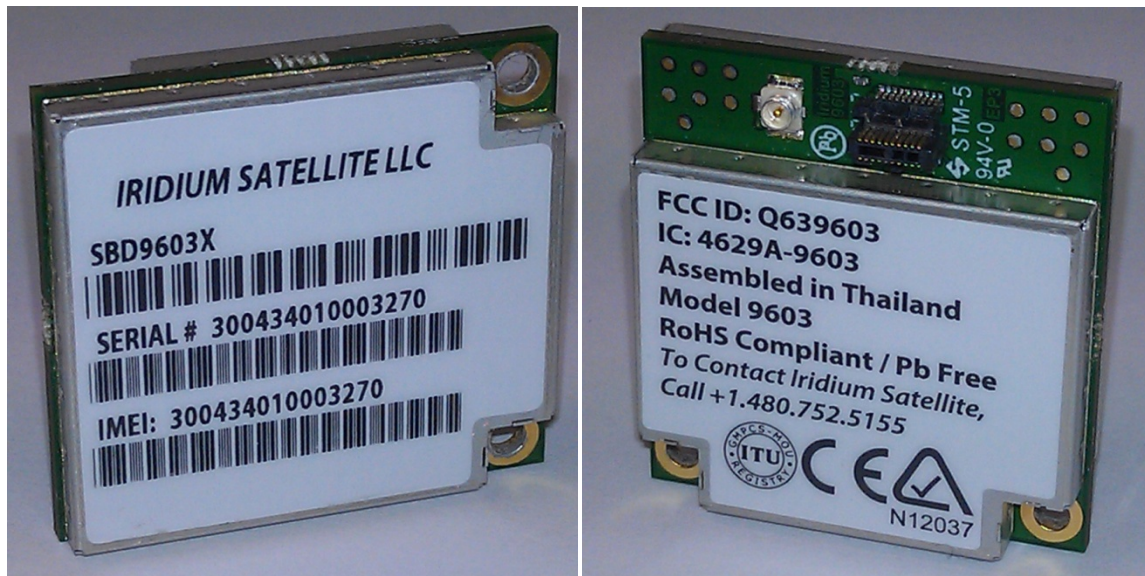

Figure 1. Iridium 9603 SBD Transceiver Front and Back Views (please note the 9603 may also reference FCC ID Q639603N and IC 4629A-9603N)

2.1 Module Dimensions

The overall dimensions of the Iridium 9603 module and its weight are summarized in Table 2. These figures are approximate and are expected to change in the next revision.

Table 2: Iridium 9603 Mechanical Dimensions and Weight

Parameter	Value
Length	31.5 mm
Width	29.6 mm
Depth	8.10 mm
Weight (approximate)	11.4g

These dimensions are subject to change for future revisions

Additionally host system Product Developers should plan space for connection to the host system motherboard, including robust and electrically grounded connections to the antenna/cable distribution system.

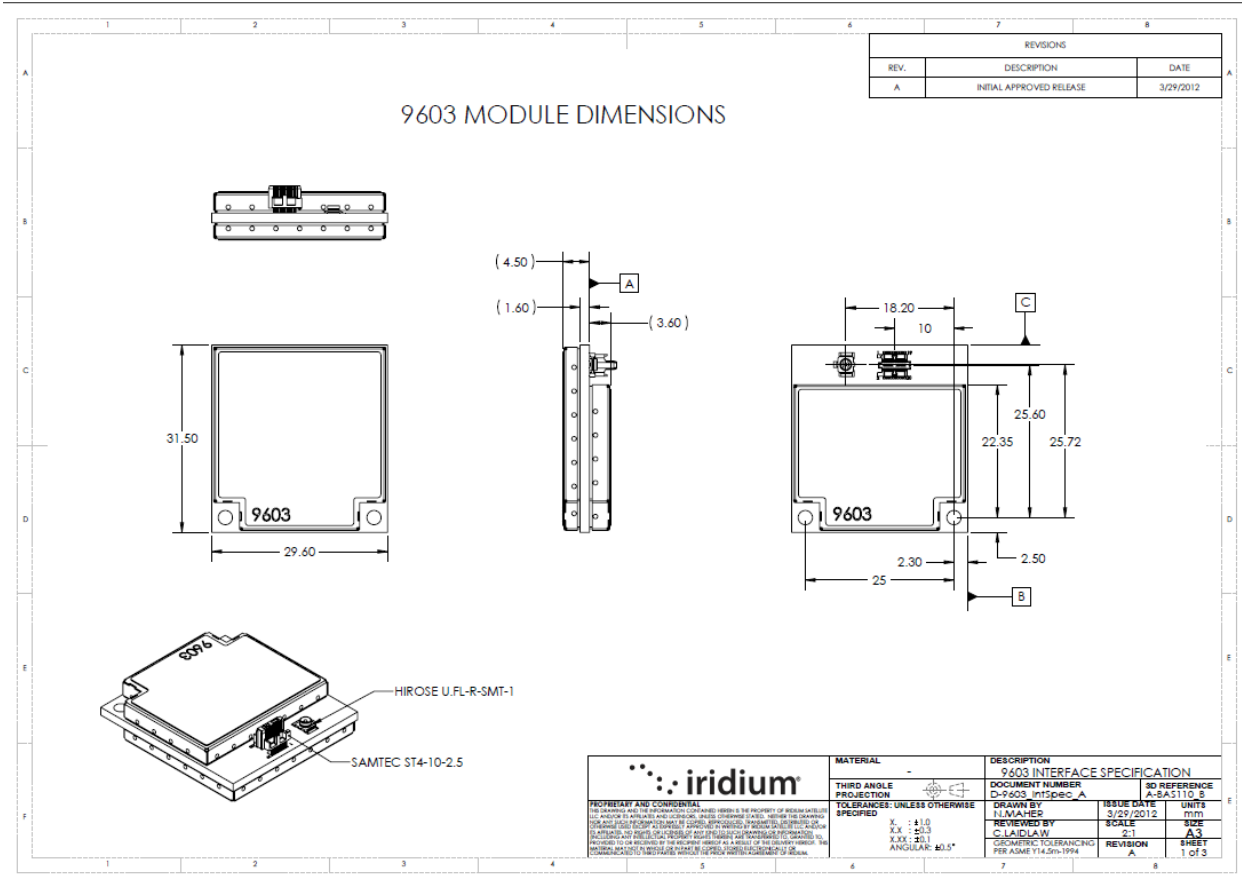

Figure 2. Dimensions of the 9603 Transceiver

2.2 Mechanical Dimensions – Motherboard Mounting

The Iridium 9603 SBD Transceiver must be fitted within an enclosed host system. With appropriate external connections, the host system motherboard and host system enclosure can be designed to meet full transceiver regulatory tests.

The Iridium 9603 SBD Transceiver is provided with two mounting holes on the opposite side from the system connector. The module should be assembled onto the motherboard of the host system, by pushing the module onto matching connectors on the motherboard and then securing the two mounting holes to the motherboard using screws.

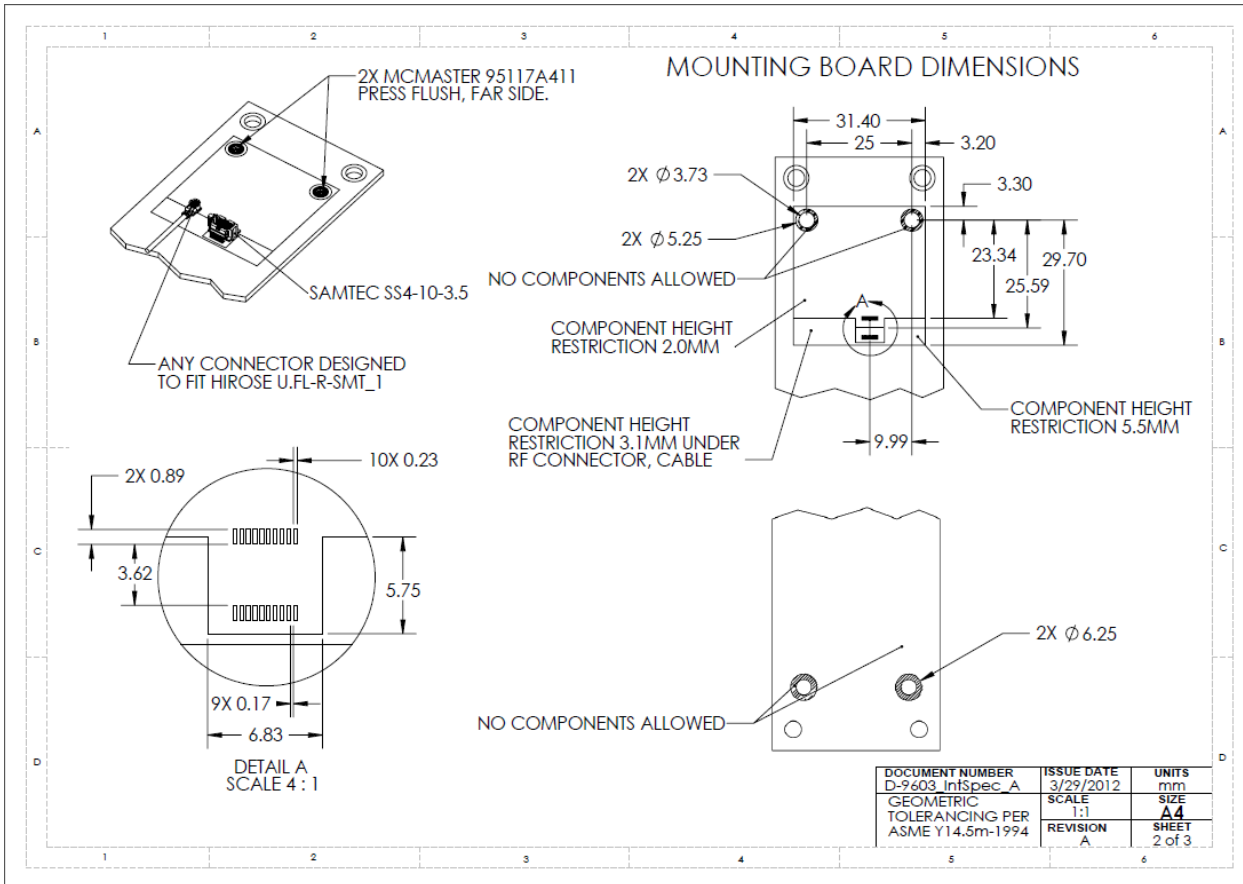

Figure 3. Motherboard mounting for the 9603 Transceiver

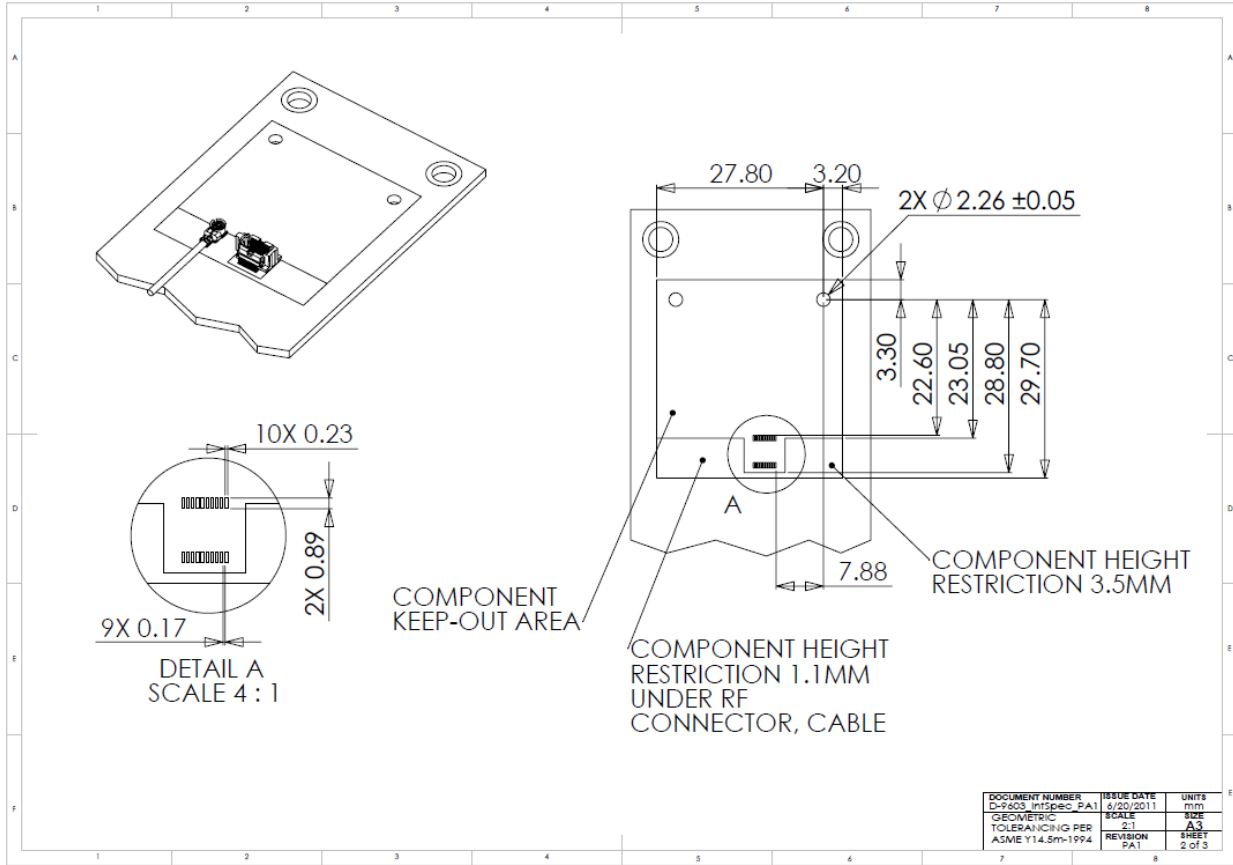

Figure 4. Connector and Mounting Detail for the Iridium 9603 Transceiver

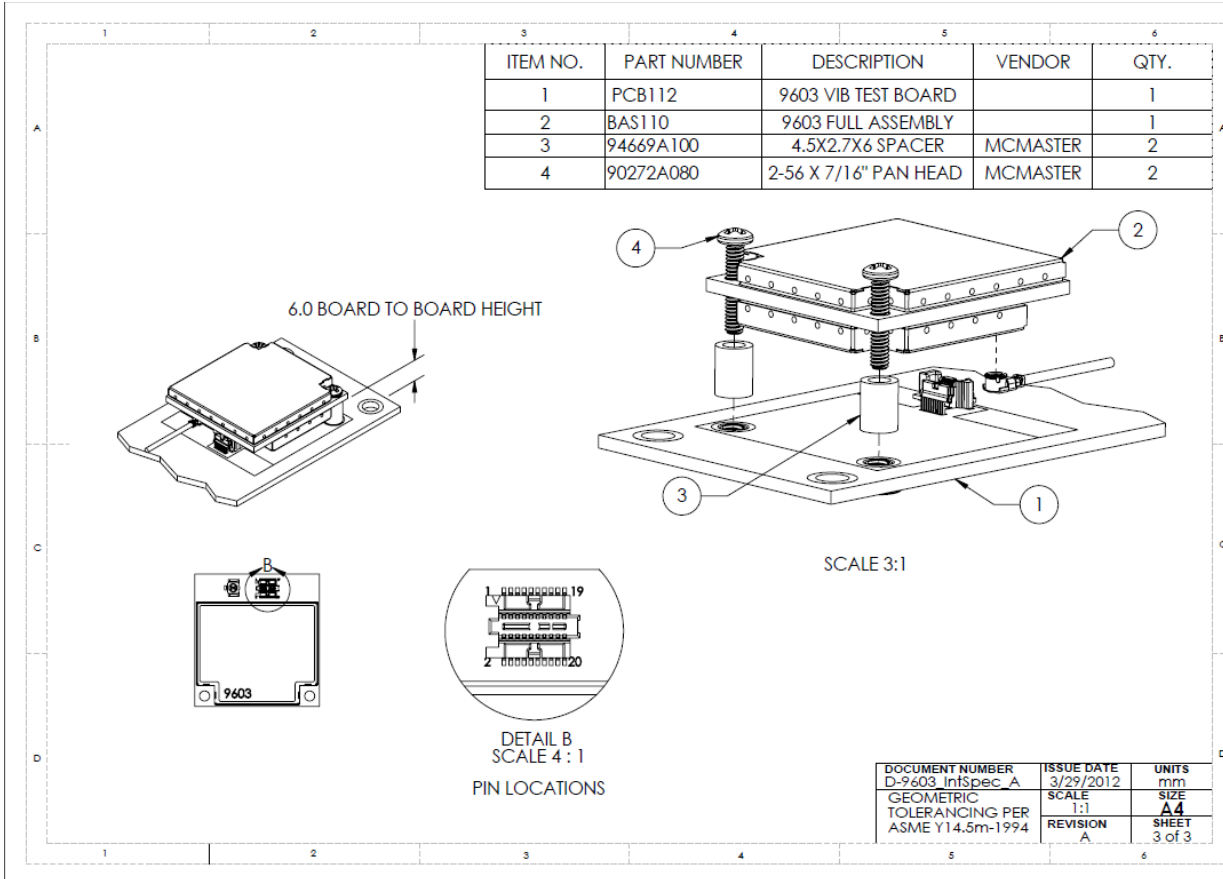

Figure 5. Motherboard mounting suggestions for the 9603 Transceiver

1. This example of a host system motherboard footprint is shown for illustrative purposes only. The host system may require a different PCB layout or mechanical arrangement.
2. The 9603 is designed to be incorporated within a host system. As such, the antenna or cable distribution system that feeds the host system should be terminated in a robust RF connector that is suitable for the end-application.
3. Safety isolation requirements for external antennas or cable distribution systems should also be taken into consideration when designing the motherboard. A suitably safe design for the RF connections should be incorporated into the host system motherboard, ideally using a chassis-bonded ground connection to the antenna cable shield.
4. The surface below the modem should be a conductive ground plane such that the modem bonds to the motherboard ground system thus reducing the possibility of radiated emissions. This also requires that the mounting screws be properly tightened to 10 cNm of torque.
5. The modem is to be installed in a “service access only” area not accessible by untrained personnel.



Use of the modem in ambient temperatures in excess of 60 degrees C will make the caseworks hot to the touch. Avoid direct contact with the modem in order to avoid burns.

2.3 Environmental

2.3.1 Environmental Specification

The environmental specifications of the final Iridium 9603 Transceiver Module are summarized in Table 5 below.

Table 5: Environmental Specifications

Parameter	Value
Operating Temperature Range	-40°C to + 85°C
Operating Humidity Range	≤ 75% RH
Storage Temperature Range	-40°C to + 85°C
Storage Humidity Range	≤ 93% RH

2.3.2 Environmental Tests Performed

The 9603 complies with the specifications listed in Table 6.

Table 6: Environmental Tests

Test Name	Test Reference	Test Description
Thermal Shock	EN60068-2-14:2009	Change of Temperature, -25°C to +70°C, 5 cycles of 1 hour each
Humidity	IEC60068-2-78:2002	Damp heat steady state 40°C 93% RH for 4 days
Vibration	IEC60068-2-64: 2008	0.96 m2/s3 from 5Hz to 20Hz 21Hz to 500Hz dropping 6dB per octave
Vibration	SAE J1455: 2012 Section 4.10	10-40Hz at 0.02g ² /Hz 40Hz to 500Hz dropping 6dB per octave
Shock	EN60068-2-27: 2009	10G peak shock over a period of 11ms, 3 shocks in 3 perpendicular orientations
Shock	SAE J1455: 2012 Section 4.11 Society of Automotive Engineers	Drop 1m onto concrete in 3 perpendicular orientations (3 drops)

2.4 Physical Interface Connectors

The Iridium 9603 SBD Transceiver incorporates two connectors:

- A multiway user connector
- An RF antenna connector

3 Electrical Interfaces

The following subsections contain information for the electrical interfaces of the 9603 SBD Transceiver for the non-RF connections. The RF interfaces are covered in section 4.4.

3.1 *User Connector*

The user connector provides the following connections to the 9603 module:

- DC power supply input
- Power on/off control
- Serial data interface
- Network available output
- Supply power indicator output

3.1.1 **User Connector Type**

The connector on the 9603 is a Samtec low-profile header connector, part number ST4-10-2.50-L-D-P-TR. Data sheets on these connectors can be found at: <http://www.samtec.com>

A suitable motherboard female socket that matches this connector is the SAMTEC header part number SS4-10-3.00-L-D-K-TR.

3.1.2 User Connector Pin Allocation

The user connector is surface mount, .4mm centerline terminal strip. Individual pin assignments are shown in Table 7 and the limits for the digital signals are listed in Table 8. Multiple supply grounds are provided and all supply and supply grounds are required to be connected to the power supply in order to limit the current on any one pin. Multiple signal grounds are provided to reduce cross-talk.

Table 7: User Connector Pin Allocation

Pin No.	Signal Name	Signal direction (WRT 9603)	Signal function	Signal level
1	EXT_PWR	Input	Supply	+5 V +/- 0.2 V*
2	EXT_PWR	Input	Supply	+5 V +/- 0.2 V*
3	EXT_GND	Input	Supply return	0 V
4	EXT_GND	Input	Supply return	0 V
5	ON/OFF	Input	On/Off control input	Analog On: >=2.0V Off: <=0.5V
6	DF_S_TX	Input	Data port, serial data input	3.3V Digital
7	DF_S_RX	Output	Data port, serial data output	3.3V Digital
8	SIG_GND	Input	Signal ground	0V
9	DF_DCD	Output	Data port, Data Carrier Detect	3.3V Digital
10	DF_DSR	Output	Data port, Data Set Ready	3.3V Digital
11	DF_CTS	Output	Data port, Clear-to-Send	3.3V Digital
12	DF_RI	Output	Data port, Ring Indicator	3.3V Digital
13	DF_RTS	Input	Data port, Request-to-Send	3.3V Digital
14	DF_DTR	Input	Data port, Data Terminal Ready	3.3V Digital
15	SIG_GND	Input	Signal ground	0V
16	Reserved			
17	Reserved			
18	SIG_GND	Input	Signal ground	0V
19	NETWORK AVAILABLE	Output	Signals when the 9603 can see an available satellite network	3.3V Digital Available = high Not available= low
20	SUPPLY_OUT	Output	Supply power indicator output	+3.3 V 5mA maximum

* Note: This is the supply voltage range of the 9603; the 9603N has an extended supply voltage range of +5 V +/- 0.5 V

Table 8: Limits for 3.3V Digital Signals

Parameter	Symbol	Min	Typ	Max	Unit
Input High Voltage	VIH	2.0		5.5	V
Input Low Voltage	VIL	-0.3		0.8	V
Output High Voltage	VOH	2.4			V
Output Low Voltage	VOL			0.4	V
Low Level Output Current	IOL			4.4	mA
High Level Output Current	IOH			5.5	mA

Figure 6 provides a reference for the pin designation. The pins are marked in the figure. Note that Pin 1 is marked on the connector.

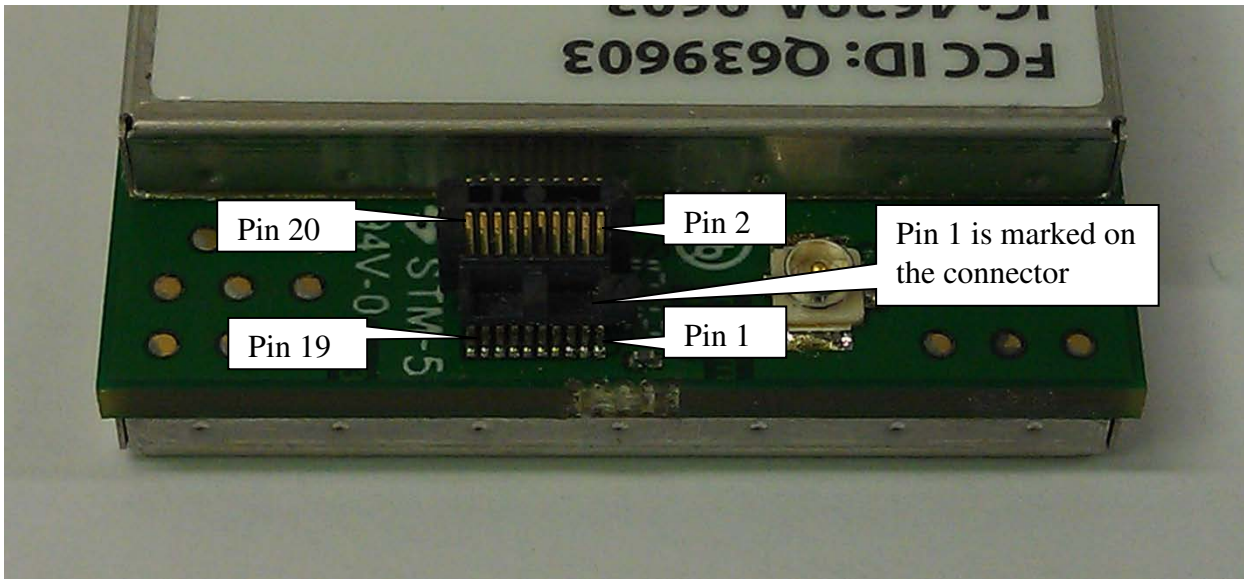

Figure 6. User Connector Pin Number Designation

3.2 DC Power Interface

The DC power interface is comprised of the DC power inputs and a control signals as summarized in Table 7. The +5V Inputs and 0V supply returns are used to supply DC power to the 9603 and ensure that enough current can be drawn across the connector without the 9603 malfunctioning during transmit due to lack of current supply. Note that all power and ground pins should be connected externally.

The DC power supply requirements for the 9603 are summarized in Table 9 below. Note that these requirements apply to DC power measured at the 9603 User connector input and not at the output of the power supply. Long power supply cables can cause a voltage drop sufficient to cause the voltage to be out of specification at the physical power supply input to the 9603.

Table 9: DC Power Input Specifications

Parameter	Value
Supply Input Voltage Range	5.0V DC +/-0.2V**
Supply Input Voltage Ripple	< 40 mV pp
<i>Typical Power Consumption at +5.0 VDC</i>	
Idle Current (average*)	34mA
Idle Current (peak)	156mA
Transmit Current (peak)	1.3 A
Transmit Current (average*)	145mA
Receive Current (peak)	156mA
Receive Current (average*)	39mA
SBD message transfer - average current*	158mA
SBD message transfer - average power*	<= 0.8 W

* Note: The average power consumption will vary depending on the view of the satellite constellation from the antenna.

** Note: Includes Tx Burst droop. This is the supply voltage range of the 9603; the 9603N has an extended supply voltage range of +5 V +/- 0.5 V

The external power supply needs to **guarantee** the following:

- The supply voltage droop over for a 8.3ms burst of 1.5A current should not be more than 0.2 Volts¹.
- The power supply should limit the in-rush² current to 4 Amps maximum
- The power source shall provide for over current protection in case of device malfunction.
- The supply noise should be less than the limits in the following profile:
 - 100 mVpp from 0 to 50 kHz
 - 5 mVpp at 1 MHz measured in 50 kHz bandwidth
 - 10 mVpp at 1 MHz measured in 1MHz bandwidth
 - 5 mVpp above 5 MHz measured in 1 MHz bandwidth.

¹ On the 9603N the supply droop should not be more than 0.5 volts.

² In rush limit refers to the impedance of the modem when it is unpowered is very low. When power is supplied from an unlimited supply the instantaneous current can exceed 4 Amps If the current exceeds this value damage can occur. This can be limited in several ways, included using a supply that cannot provide more than 4 Amps instantaneously; or providing some series inductance/resistance to the supply lead.

3.2.1 Power On/Off Control

An external on/off input is provided on a pin of the User connector. The 9603 starts up when power is applied and the power on/off input is high. As long as the input voltage is applied, logic high on this line turns the transceiver on and a logic low turns it off. If this line is not required then it must be connected directly to the +5 V supply.

Note that this on/off control is similar to the Iridium 9601 and 9602 products, but it is **not** the same as the 9522, 9522A or 9522B products.

Prior to turning off the modem a “flush memory” (AT*F) command should be issued to ensure all memory write activity is completed. When a transceiver has been turned off, Product Developers should not reapply power on a unit until more than 2 seconds has elapsed after power has reached 0V. Additionally, if a unit does not respond to AT commands, power off the module, wait for 2 seconds and then power it back on.

When a 9603 is powered off the power on reset circuit requires 2 seconds for voltages to decay. If the 2 second wait time is not adhered to the reset circuit may not operate and the modem could be placed in a non-operational state. The state is not permanent and can be rectified by the above procedure.

3.2.2 Typical Power Usage Profile

This section is designed to give the Product Developer some insight to the electrical power profile that the 9603 uses. It does not describe every situation and permutation possible. It should be used as a starting point for the Product Developer to continue its own development design. The actual usage profile can vary for a number of reasons:

- 1) View of the sky – if in poor visibility of the sky where a clear line of sight is not available between the transceiver and the satellite.
- 2) The higher the antenna VSWR the higher the current consumed
- 3) How often the 9603 module is activated/deactivated by the Host Controller system
- 4) Manufacturing variation from transceiver to transceiver.

The host system designer should ensure their design covers for worst case power consumption scenarios.

3.3 *Serial Data Interface*

The data/fax serial interface is an RS-232 9-wire interface at 3.3V digital signal levels over which the 9602 and FA transfer commands, responses, and SBD message data. With respect to this interface, the 9602 behaves as a DCE (Data Communication Equipment), and the FA behaves as a DTE (Data Terminal Equipment).

If RS-232 voltage levels are needed, the FA must include an LVTTTL/RS-232 level-shifter. Autobaud is not supported. The baud rate can be set via the AT+IPR command. The default rate is 19200 bps.

See the ISU AT Command Reference Specification for information on the data/fax interface.

3.4 *Network Available Output*

This is a digital output that can be used by an application to know when the transceiver has visibility to the satellite network. This is useful in applications where the transceiver may move around terrain that reduces the amount of time that clear line of sight to the satellite constellation is available. The Product Developer can use this output to preserve battery life by reducing the number of attempted transmissions by including this logic output in the application decision logic.

Network Available means only that the 9603 can successfully receive the Ring Channel, or, put more simply, it can see an Iridium satellite. Network Available is not a guarantee that a message can be successfully sent. The Network Available state is evaluated every time the Ring Channel is received or missed. If the Ring Channel is visible, then that is typically every 4 seconds. If the Ring Channel is not currently visible, then the update period can be as long as 2 minutes, depending on how long the lack of satellite visibility existed. This is because the 9603 attempts to conserve power by increasing the ring search interval while the satellites are not visible. Every time a ring search fails, the time to wait is increased and eventually limits at 120 seconds.

If Network Available is currently off, the Field Application may still attempt an SBDI[X] session. This will force the 9603 Transceiver to look for the Ring Channel immediately, and on finding it, to attempt to send the message. In this case Network Available will not come on immediately. The Network Available does not turn on while in a +SBDI session. It will however turn on 4 seconds later assuming that the Ring Channel is present. After the SBD session completes, the 9603 performs a new Ring Channel search sequence, at the end of which Network Available gets turned on. That can take between 4 and 12 seconds.

The wait time between search windows is reset to 4 seconds every time a search succeeds. Otherwise it continues to increase. So if the +SBDI attempt fails to find the ring channel, the search window does not reset to 4 seconds.

Note that the behavior of +CIEV:1 is identical in to that of the Network Available output.

3.5 *DC Supply Indicator Output*

A DC supply indicator signal is provided by the 9603 which could be used directly for driving an LED to provide a visible indication that the Transceiver supply is on. Alternatively the output signal could be used in application logic to determine if the internal Transceiver power supply is on.

4 RF Interface

This section describes the physical characteristics of the RF connectors and specifications of the RF Interface.

4.1 RF Connector

The 9603 RF connector is a U.FL connector produced by Hirose. The part number is U.FL-R-SMT-1. This is a surface mount connector that is directly attached to the 9603 module. The U.FL connector mates with a pigtail which can link to an antenna.

Note - this 9603 module has a different antenna connector than other Iridium transceivers.

Note that for safety reasons, the RF connector on the 9603 module should not be directly connected to an external antenna cable or cable distribution system. Paragraph 7.3 of EN60950-1:2006 safety standard requires that users are protected against high voltages that might appear on these cables. This can be achieved either by inserting a high-voltage isolating capacitor in series with the signal or by grounding the shield of the coaxial cable. The 9602 RF connector has limited voltage capacity; therefore, protection needs to be provided in the host application. Developers are encouraged to review the EN60950-1:2006 standard for additional details.

4.2 Antenna Implementation

4.2.1 Antenna Characteristics

The 9603 should be connected to an Iridium-band antenna with the following antenna connector characteristics as described in Table 11.

Table 11: Antenna Characteristics

Parameter	Value
Impedance	50 Ohms nominal
Gain (maximum)	3dBi
Polarization	RHCP
VSWR (in Iridium band)	1.5:1
VSWR (out of band)	3:1

4.2.2 Important Design Guidance

The 9603 requires a load, i.e. antenna plus cable, to present a VSWR of less than 3:1 over the frequency range of 1.2 GHz to 2.0 GHz at the 9603 RF connector. This is the out-of-band VSWR requirement. In the event a particular antenna design does not meet the out-of-band VSWR requirement, a combination of cable loss and passive attenuation, i.e. an attenuator, can be used to satisfy the out-of-band VSWR requirement provided the total attenuation, cable plus attenuator, between the 9603's RF connector and antenna does not exceed 3 dB. A minimal amount of attenuation should be used to meet the out-of-band VSWR requirement for best performance as well as a lower VSWR in the Iridium band.

Note:

- The above design guidance applies only to 9603 and not 9603N
- Existing certified antennas will require different RF connector types than those for the 9601, 9602, 9522, 9522A and 9522B

4.3 RF Interface Specifications

The RF interface requirements for the 9603 are summarized in Table 12 below.

Table 12: General RF Parameters

Parameter	Value
Frequency Range	1616 MHz to 1626.5 MHz
Duplexing Method	TDD (Time Domain Duplex)
Input/Output Impedance	50Ω
Multiplexing Method	TDMA/FDMA

4.4 Radio Characteristics

Table 13 contains radio characteristics of the 9603 SBD Transceiver.

Table 13: Radio Characteristics

Parameter	Value
Average Power during a transmit slot (max)	1.6 W
Receiver sensitivity (Typical level at module connector)	-117dBm
Max Cable loss permitted (Note 1)	2dB
Link Margin – Downlink (Note 2)	13dB
Link Margin – Uplink (Note 2)	7dB

Note 1: Cable losses should be minimized. The total implementation loss for an antenna, connectors, cable, lightning arrestor and any other RF component between the transceiver and the antenna should not exceed 3dB. The total cable loss between the antenna and the modem includes losses in the motherboard. Implementation loss higher than this will affect the Iridium link performance and quality of service. Solutions with a loss higher than 3dB will not meet the requirements of Iridium Solution Certification.

Note 2: Link Margins are given assuming a free-space propagation model.

4.5 S-meter Performance

The numbers “reported over the AT command interface indicate the signal strength of the ring channel. Care should be taken when using the S-meter readings for comparisons between devices. Of particular note are the following:

1. There is a 0.5 dB tolerance on calibrating the S-meter.
2. Each bar represents a 2 dB increment
3. Multiple ring channels can be present at the same time so units can lock to different signals.
4. If the reading is near the decision threshold it would be easy to see a 1 bar difference

5 AT Command Set Description

The 9603 is configured and operated through the use of AT commands. See the “ISU AT Command Reference” for the full set of AT commands and responses. Note that versions 3.2 and earlier of the ISU AT Command Reference do not mention the 9603. Subsequent versions of the reference will do so. At the time of writing of this version of this document, all information contained in the ISU AT Command Reference for the 9602 applies equally to the 9603. For differences in AT command support between 9603 software releases, see the relevant software release notes, which are made available to authorized Iridium VARs and VAMs on the Iridium Developer Extranet. It is the responsibility of Product Developers to check compatibility of applications software with the AT Commands on all 9603s used for both development and commercial deployments. See also the “Iridium Short Burst Data Service Developers Guide” for information on how SBD operates on the Iridium system.